

## Press O-500/390 for the Granulation of Pasty Products

Granulation (pelleting) of raw materials, finished products, and waste can be achieved economically utilizing our "horizontal flat die extrusion press" compacting system.

For processing of pasty products, the type O series = overhead drive has been developed. These presses are for example appropriate for catalysts, pigments, washing agent additives, clay, vulcanization accelerators, and instant vitamin C products.

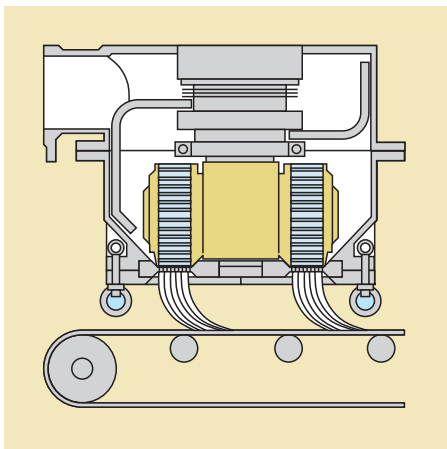

Press with overhead drive

Directly after leaving the die, the pellets can be fed onto a conveying element – free from mechanical stress. Therefore clogging of the discharge devices as with standard presses and agglomerations of the pellets are avoided.

The press is made of stainless steel and works on the well-proven flat die principle.

Main machine bearings and roller bearings are provided with a long-term lubricant and with special seals.

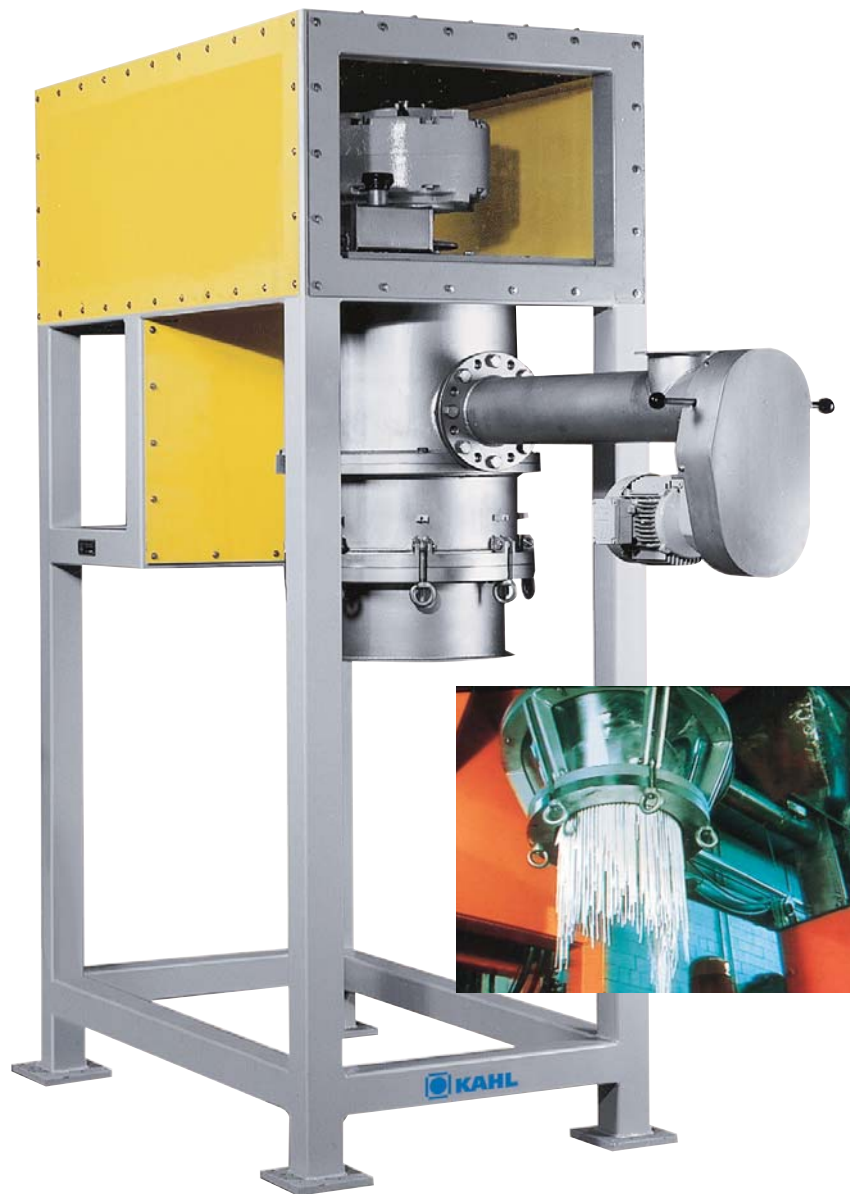

# Press O-500/390

## Technical data

### Pellet diameter

0.6 - 15 mm

0.6 - 2 mm (only with perforated plates)

2 - 15 mm (only with dies)

The press is driven by a three-phase current motor, a V-belt drive, and a slip-on gear.

### Hydraulic system of the pan grinder head

The pan grinder head is equipped with a hydraulic pan grinder head adjustment. With this system, the distance between rollers and die can be modified during operation. Thus the thickness of the product layer can be influenced and adapted to the requirements of the product.

### Technical options

- Roller drive for products with extreme slipping properties
- Roller gap control unit for products with high quality demands
- Inner die support to absorb the pressure forces at the inner ring of the perforated plates/dies

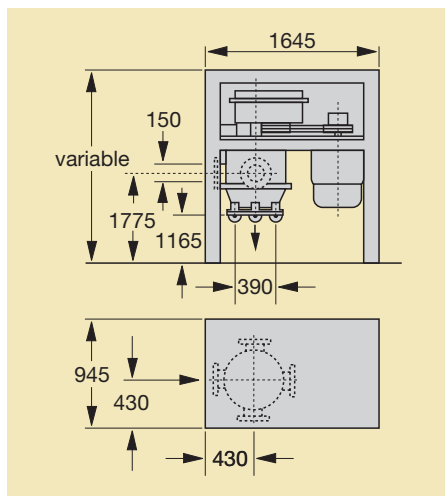

**Type 24-390**

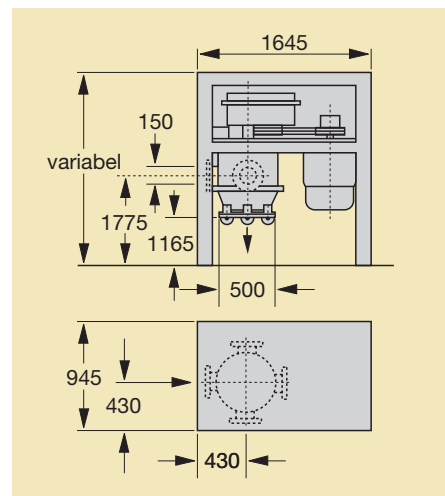

**Type 25-500**

Die diameter	390 /500 mm
Roller diameter	230 mm
Roller width	77 mm
Number of rollers	2/3
Drive motor	22 – 30 kW
Circumferential roller speed	1.5 to 3.0 m/s
Machine weight with motor, gear and support frame	2000 kg

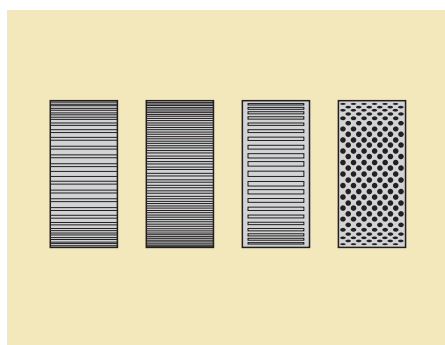

Product-dependent roller profiles



**AMANDUS KAHL GmbH & Co. KG**

Dieselstrasse 5-9  
D-21465 Reinbek / Hamburg  
Phone: +49 (0)40 727 71 - 0  
Fax: +49 (0)40 727 71 - 100  
info@amandus-kahl-group.de  
[www.akahl.de](http://www.akahl.de)